

A 0.75 Million-Point Fourier Transform Chip for Frequency-Sparse Signals

Ezz El-Din Hamed

Omid Abari, Haitham Hassanieh, Abhinav Agarwal, Dina Katabi,
Anantha Chandrakasan, Vladimir Stojanović



Leverage Sparsity

- Output of FFT is Sparse:
 - Most frequencies have zero energy or noise
 - Only few frequencies are active and have energy
- Use sparse FFT algorithm
 - Find and compute the active frequencies

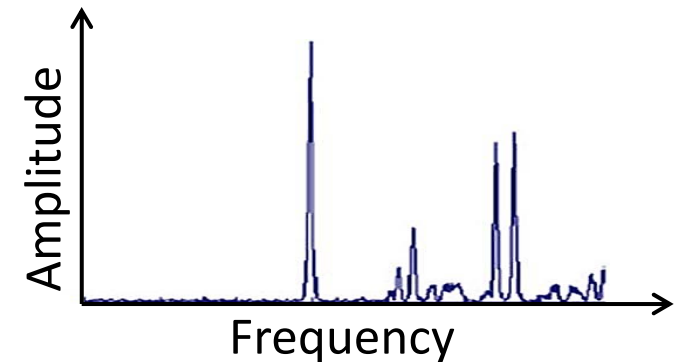

Applications

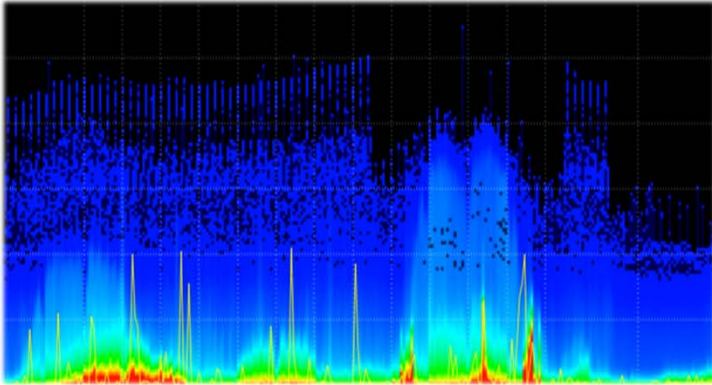

Spectrum Sensing



GPS



Radio Astronomy

- GHz spectrum sensing and acquisition
- Pattern matching by convolution with long code (e.g. GPS)
- Radio astronomy: data compression

Wideband Spectrum Sensing

Occupancy Graph

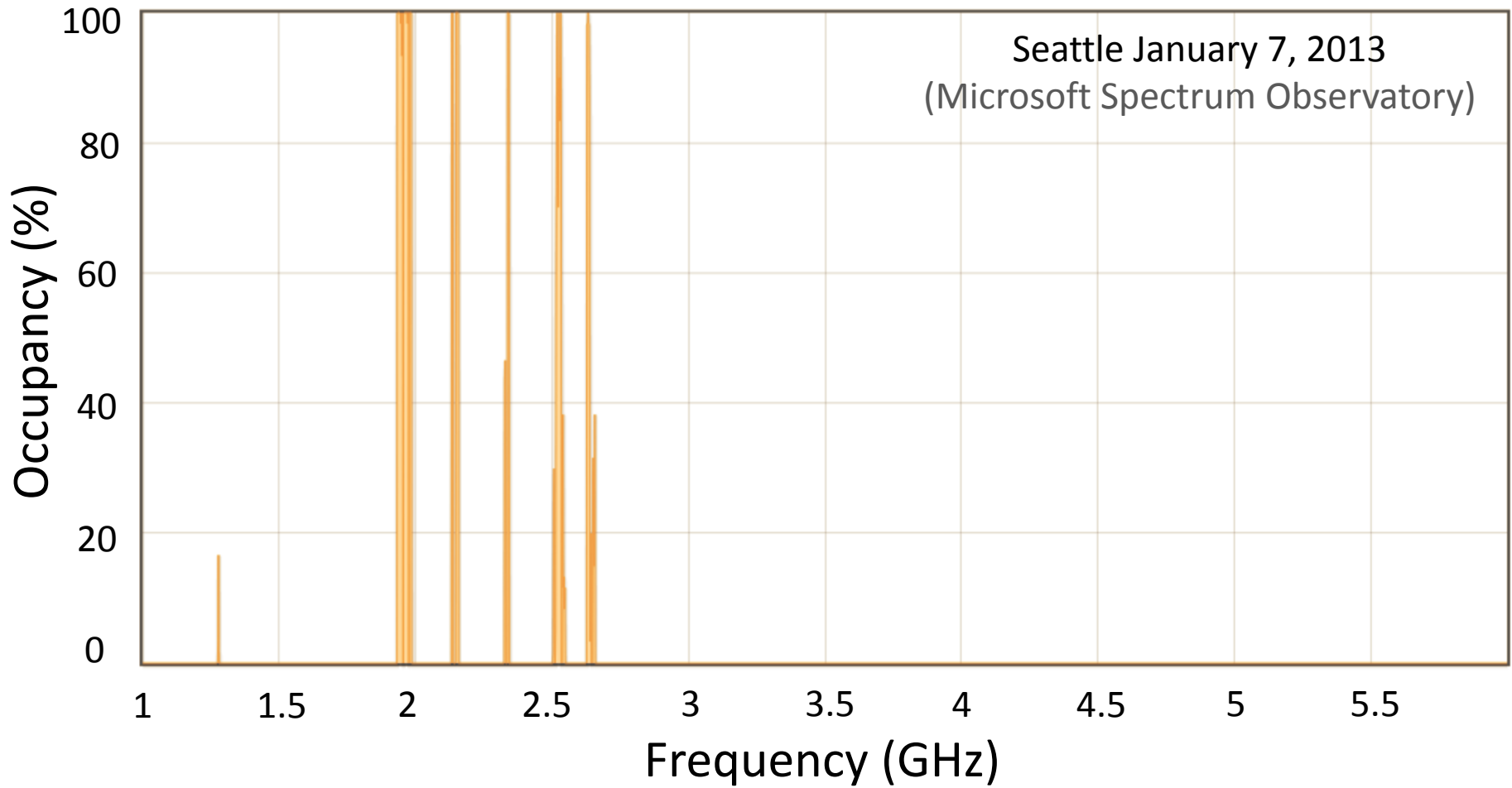

Outline

- Sparse FFT Algorithm
- Micro-architecture and Implementation
- Measurement Results
- Conclusion

How Does Sparse FFT Work?

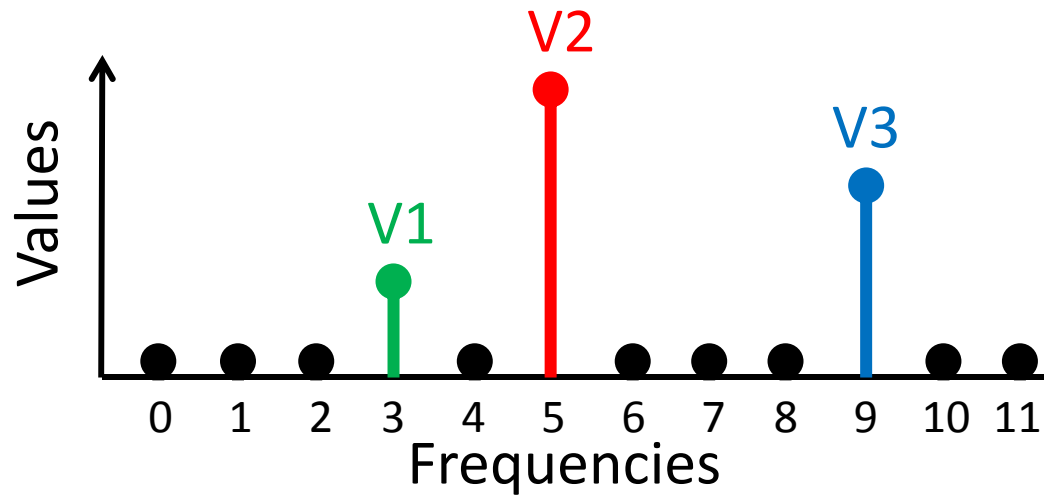

1. Bucketize
2. Estimate
3. Resolve collisions

How Does Sparse FFT Work?

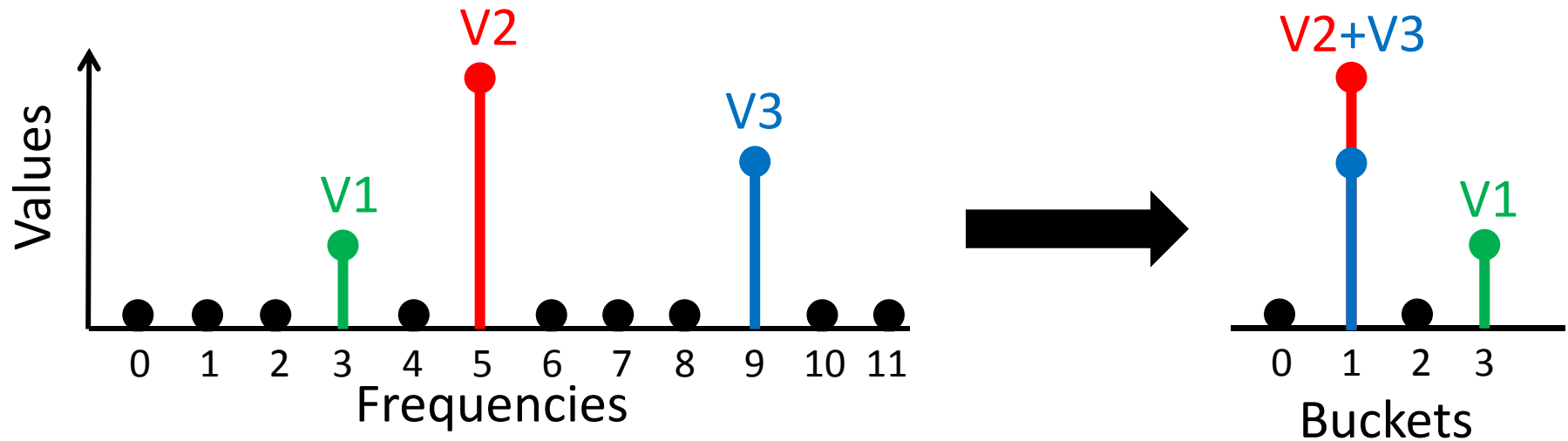

1. Bucketize

Sub-sampling time \rightarrow Aliasing the frequencies

How Does Sparse FFT Work?

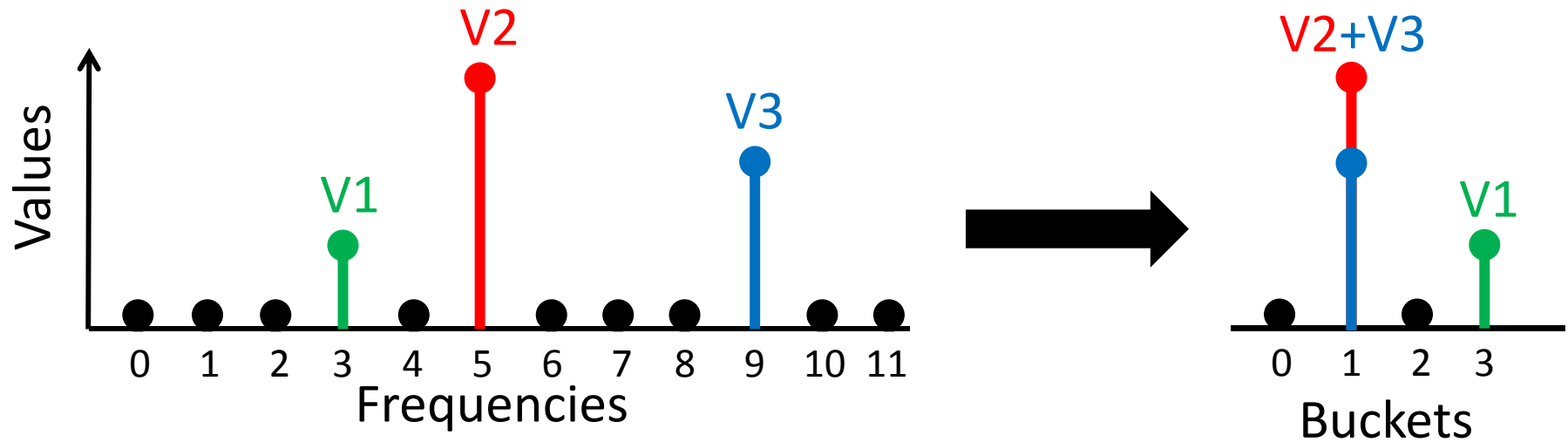

2. Estimate

How Does Sparse FFT Work?

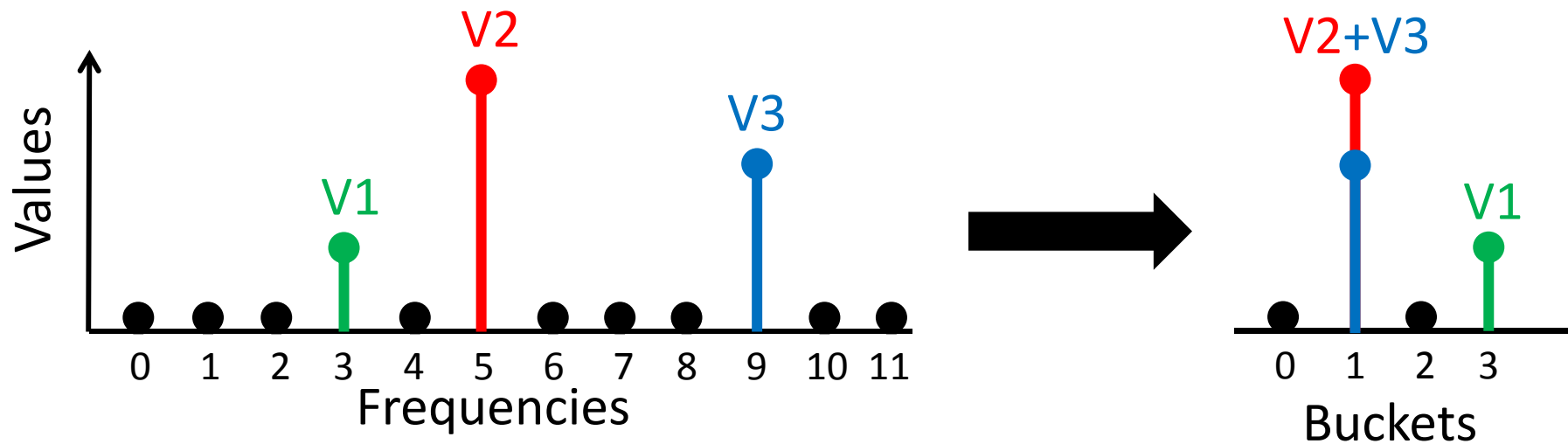

2. Estimate

Repeat bucketization with a **time shift τ**

Time-Domain

$$x(t)$$

$$x(t - \tau)$$

Freq-Domain

$$X(f)$$

$$X(f)e^{-j\theta}$$

Phase Rotation

$$\theta = \frac{2\pi f \tau}{N}$$

How Does Sparse FFT Work?

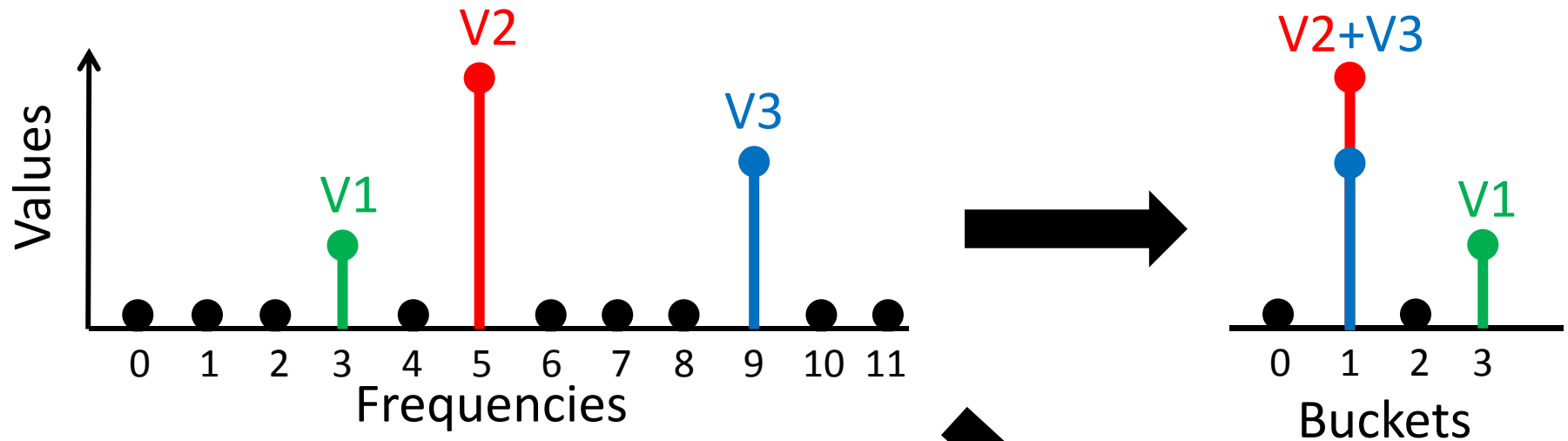

3. Resolve Collisions

Repeat bucketization with a different subsampling rate (co-prime)

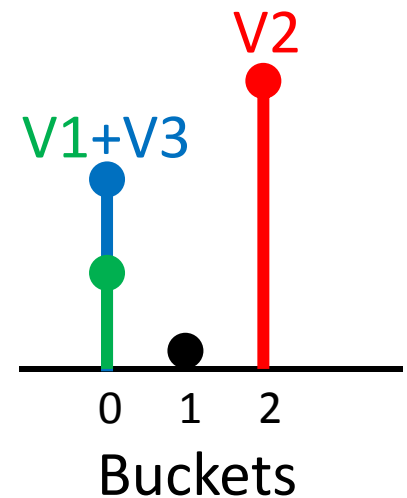

Implementation of Sparse FFT

- Sparse FFT size: $N=3^6 \times 2^{10}=746496$
 - Subsample by 3^6 in time \rightarrow FFT of size 1024 (2^{10})
 - Subsample by 2^{10} in time \rightarrow FFT of size 729(3^6)
- Sparsity: outputs up to **750** active frequencies
- Output resolution: **12 bit** real, **12 bit** imaginary

Sparse FFT Chip Block Diagram

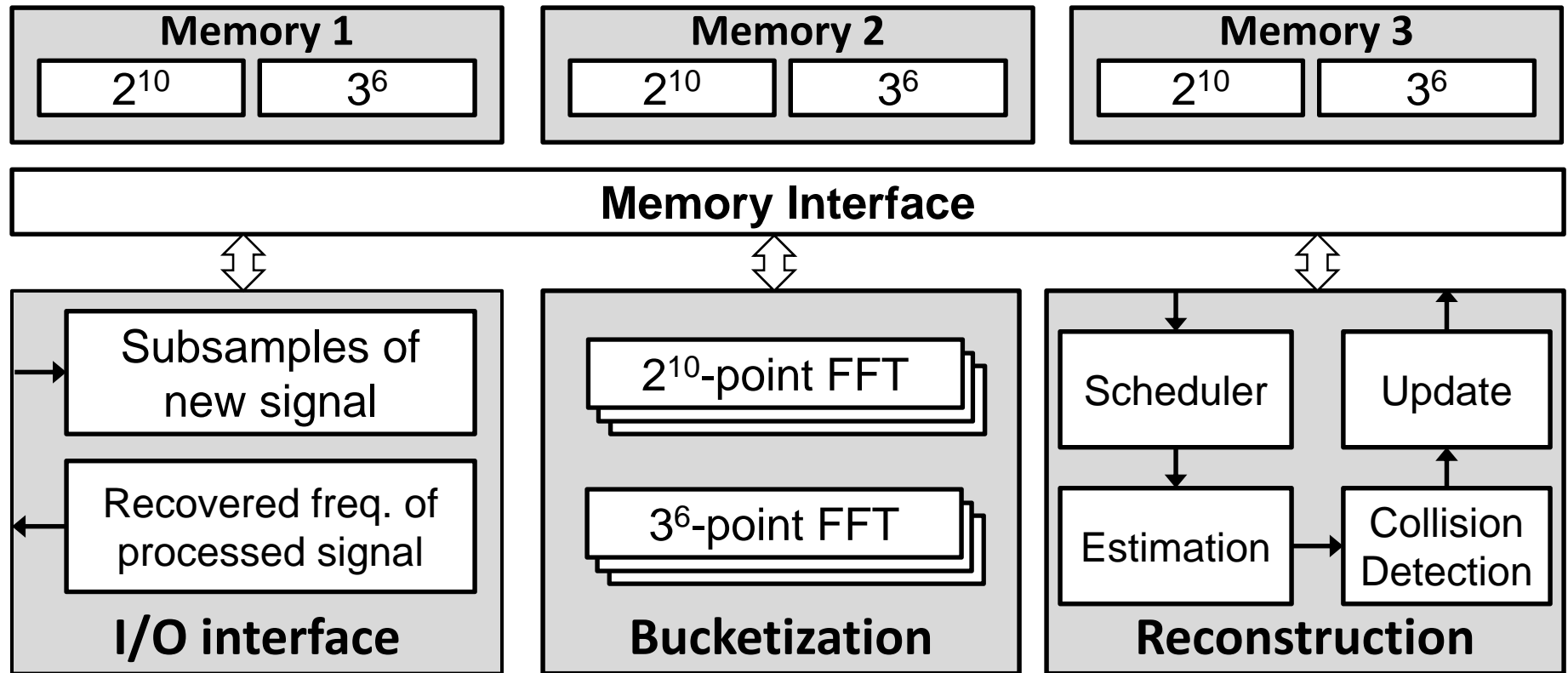

3 Pipelined Stages

Sparse FFT Chip Block Diagram

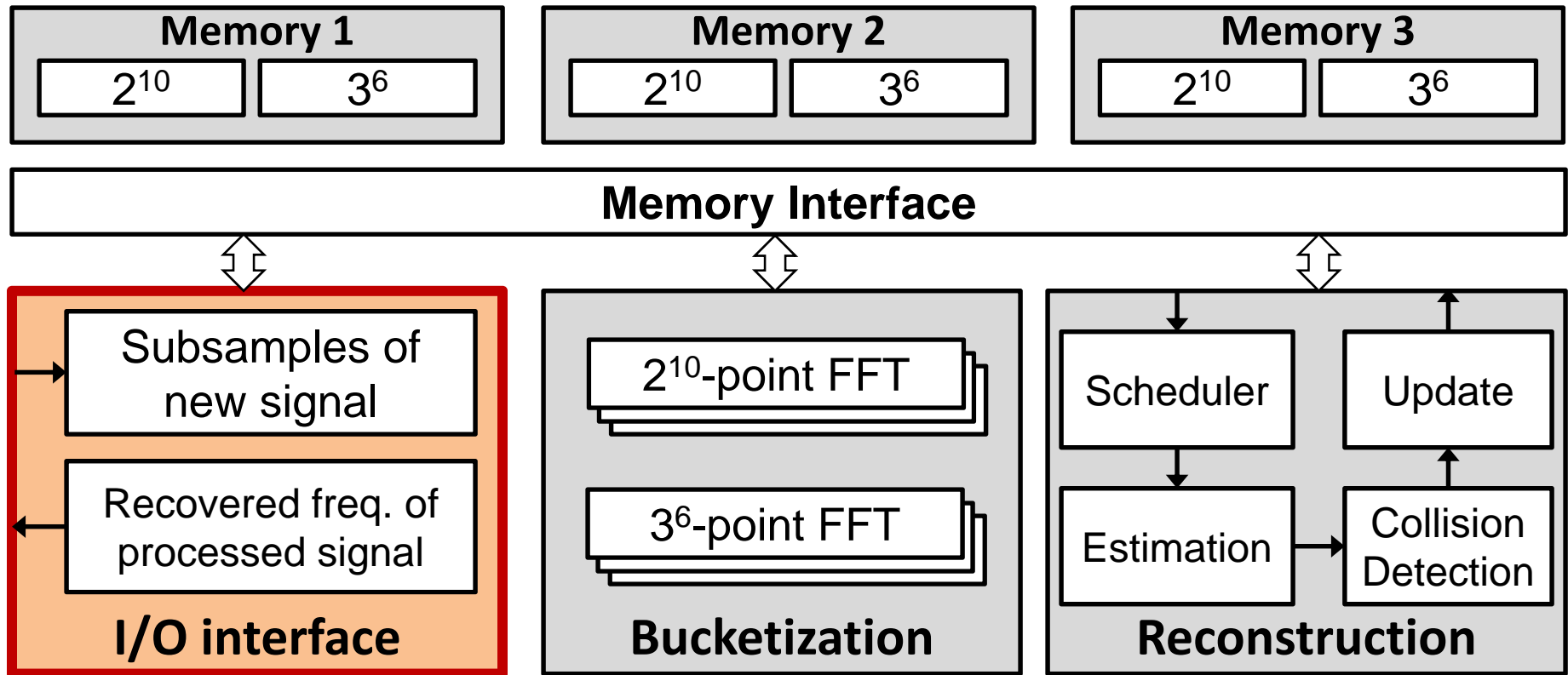

- **Input:** sub-sampled signal (by 2^{10} and 3^6)
- **Output:** positions and complex values of active frequencies

Sparse FFT Chip Block Diagram

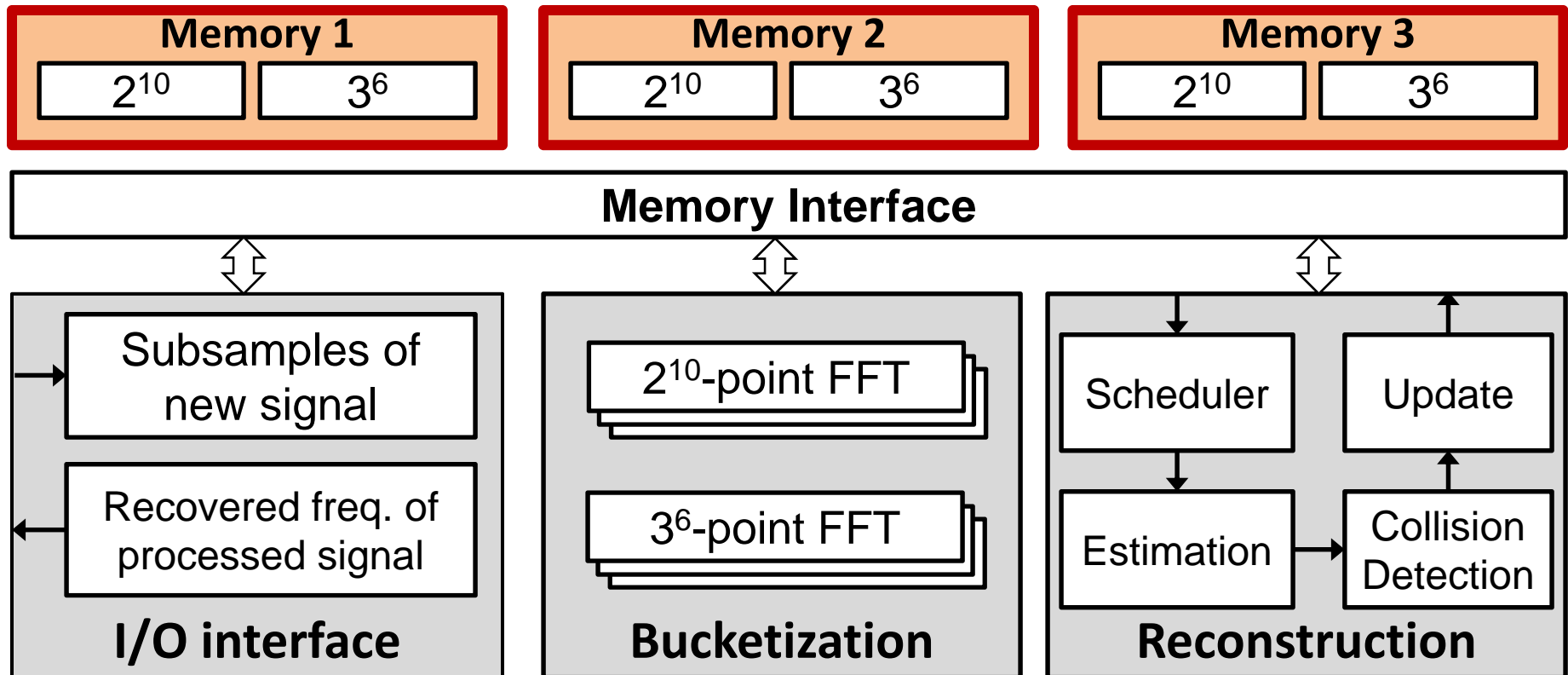

- 3 Memory sets, 2 SRAM blocks each
- Rotated across the 3 pipeline stages

Sparse FFT Chip Block Diagram

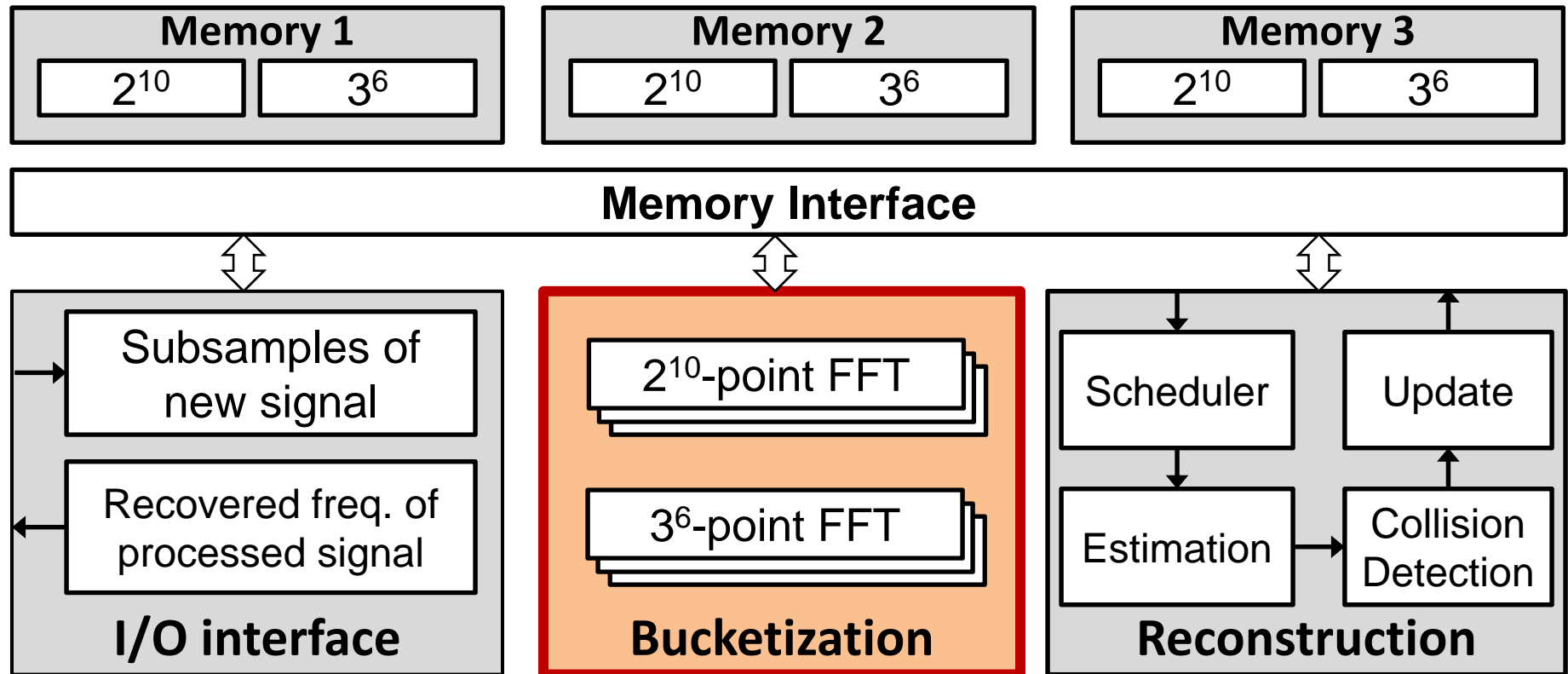

- In-place FFT
 - Radix-4 butterfly for 2^{10} -point FFT
 - Radix-3 butterfly for 3^6 -point FFT
- Three FFTs of each type sharing the memory

2¹⁰ FFT Architecture

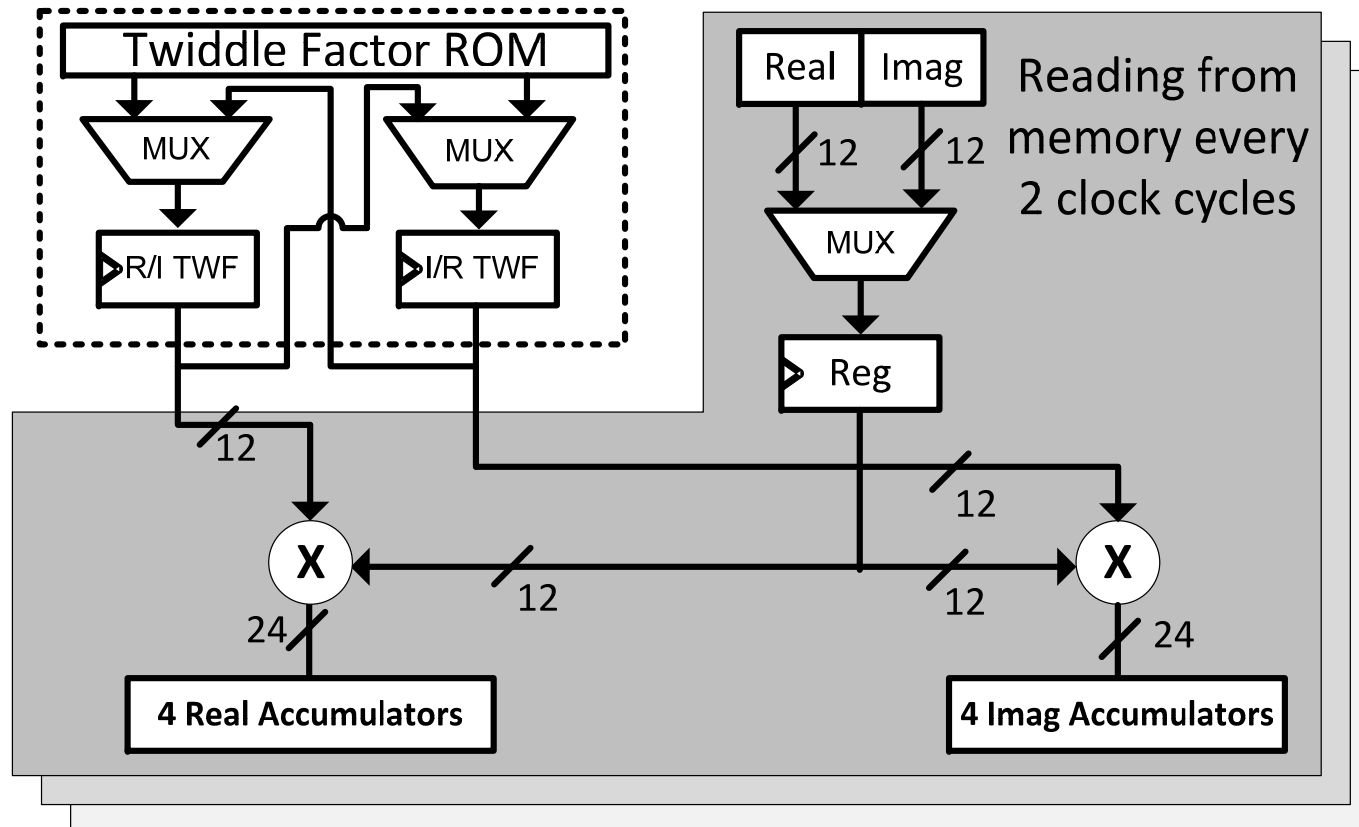

- Three radix-4 butterflies running in parallel
- Two 12b x 12b real multipliers per butterfly
- Multiplexing Real and Imaginary

2^{10} FFT Architecture

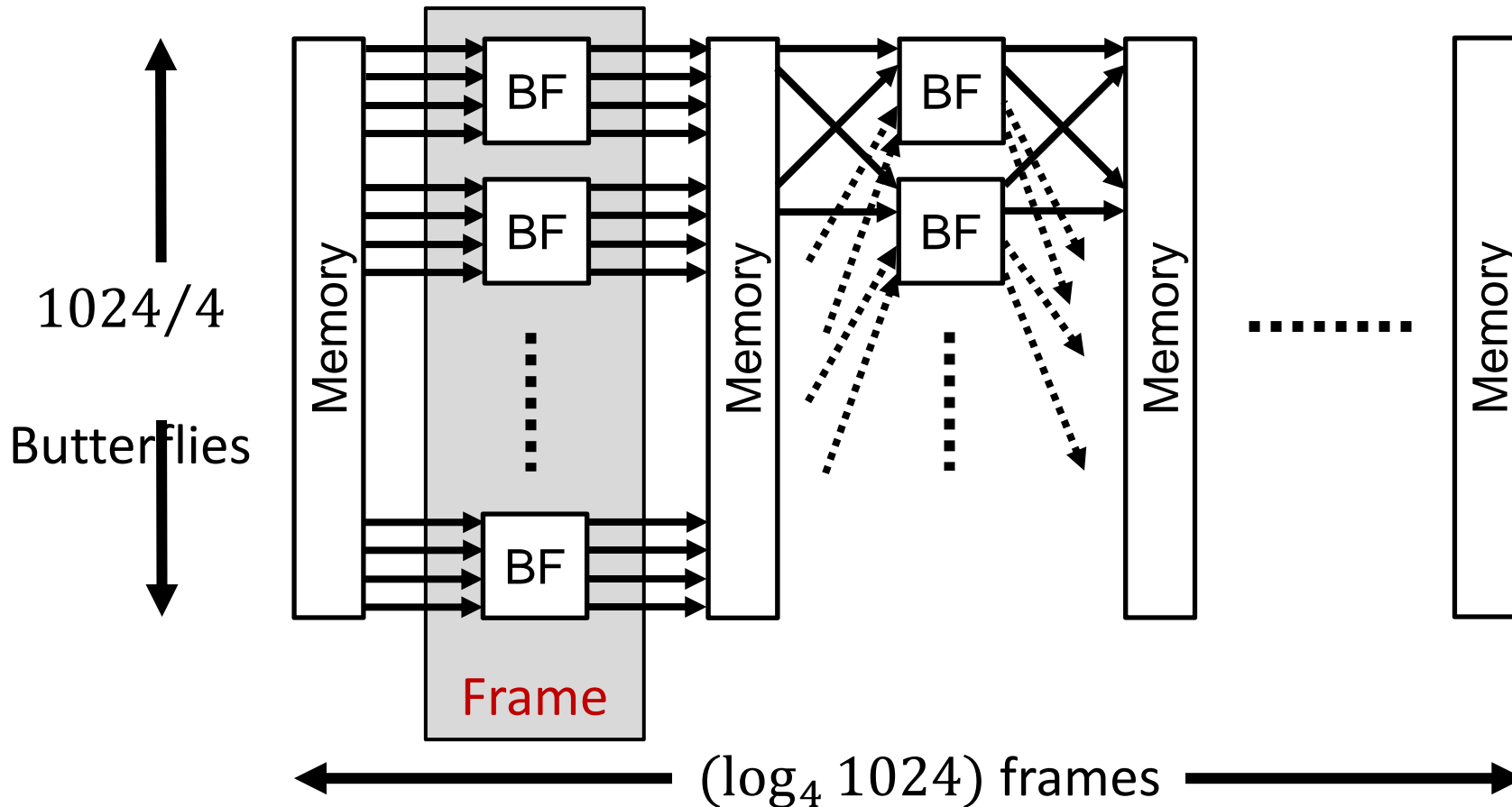

- In-place 1024-point FFT using a radix-4 butterfly
- 1024 additions (10 extra bits to account for overflow)

Dynamic Scaling

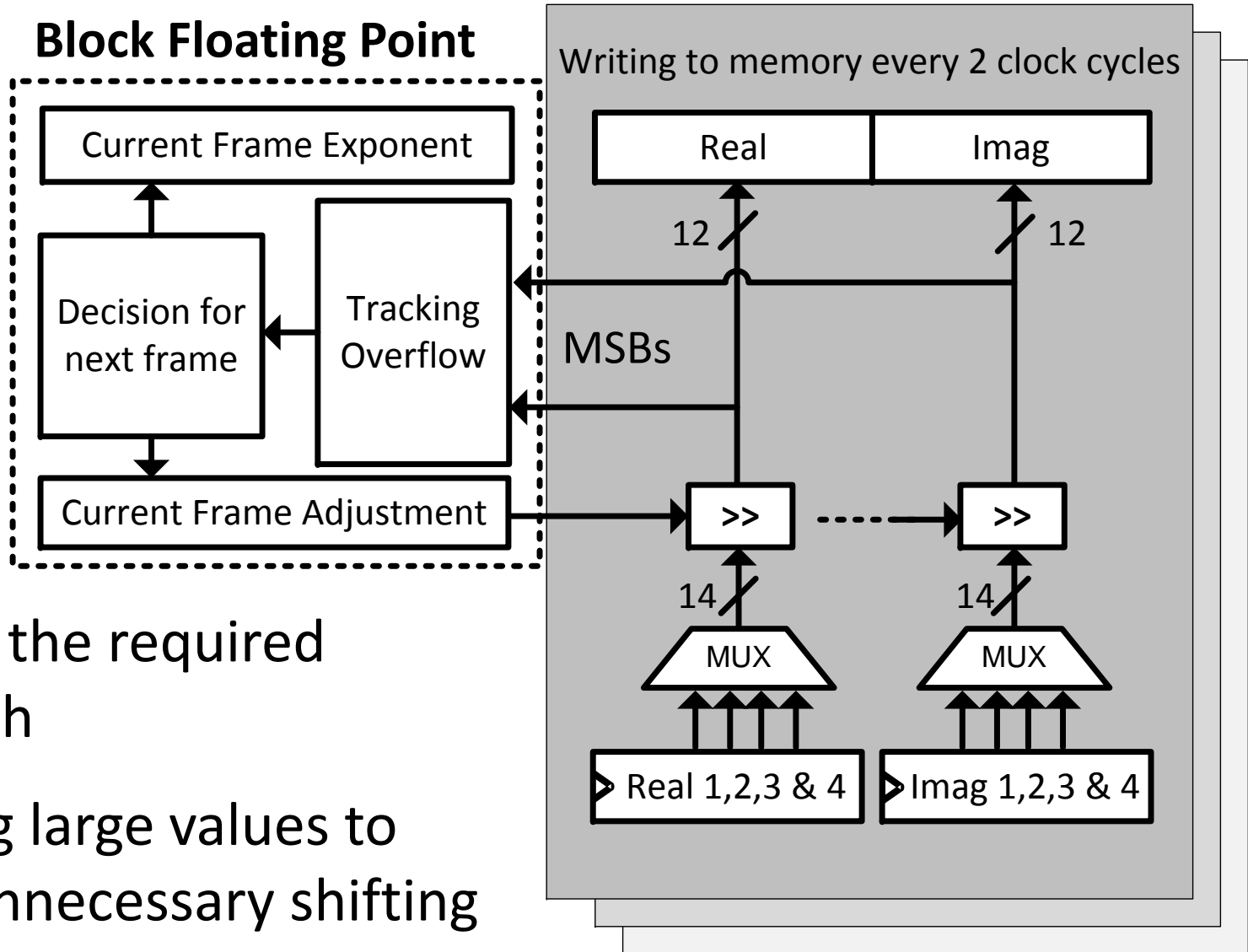

- Reduce the required bit width
- Tracking large values to avoid unnecessary shifting

Sparse FFT Chip Block Diagram

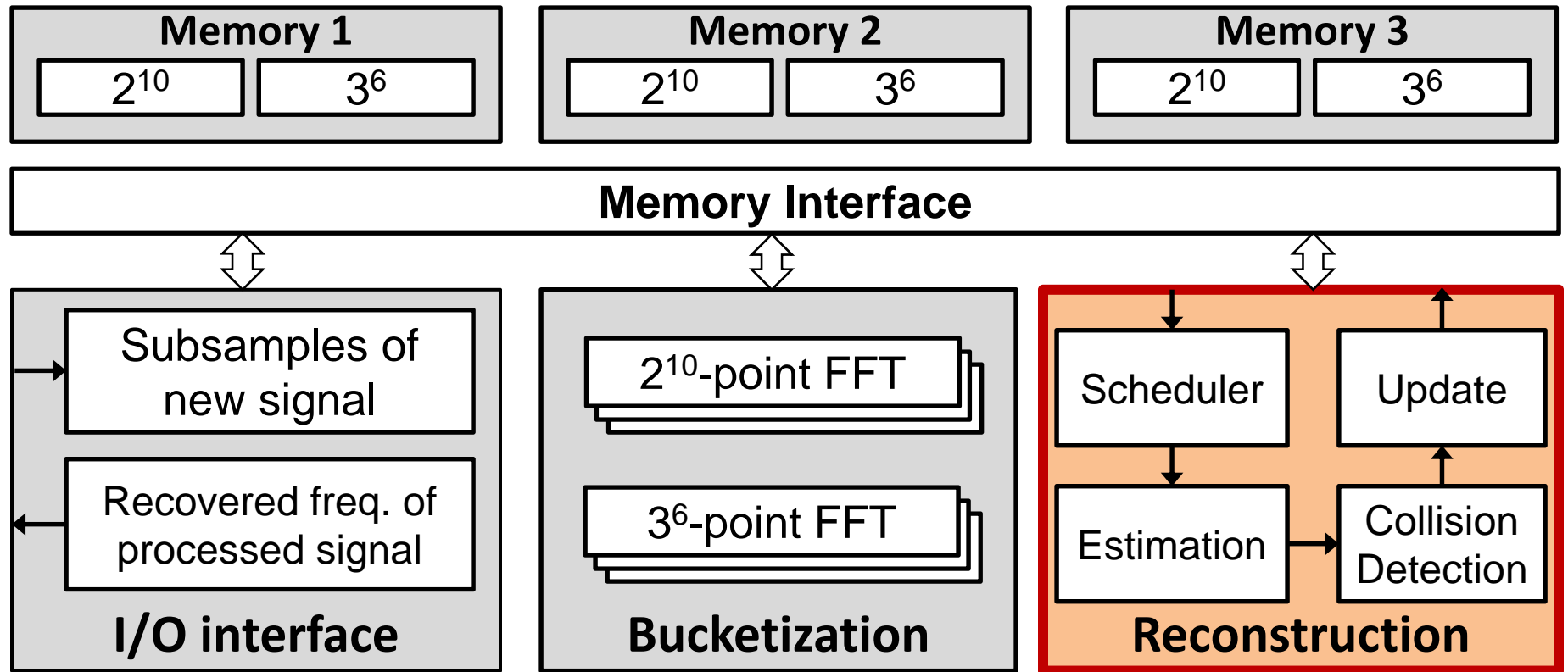

Reconstruction stage has 4 sub-blocks

Sparse FFT Chip Block Diagram

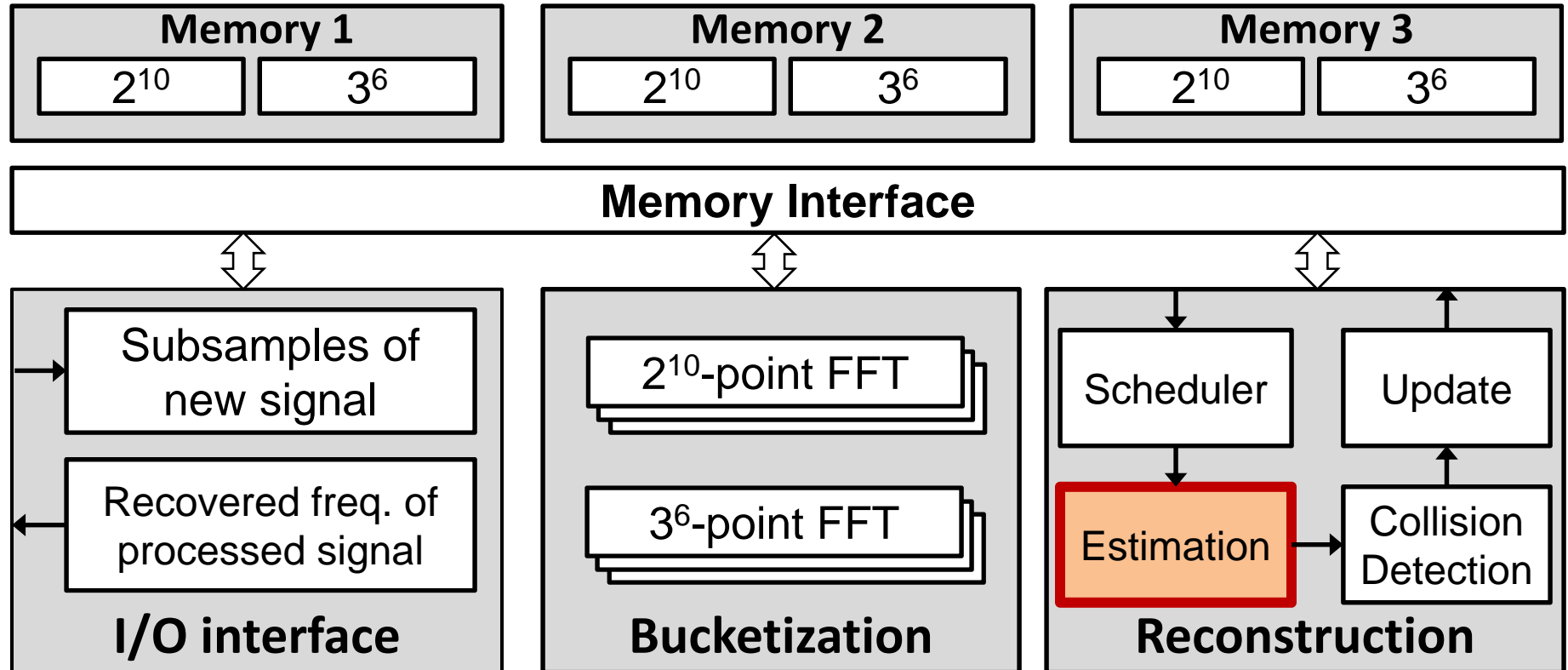

Estimation Sub-block

- Estimate frequency position f where $0 \leq f \leq N - 1$
- For $N \approx 0.75$ million \rightarrow Use 20 bits to represent f

Estimation Sub-block

- Estimate frequency position f where $0 \leq f \leq N - 1$
- For $N \approx 0.75$ million \rightarrow Use 20 bits to represent f
- For 2^{10} bucketization: frequency f aliases to bucket number b :

$$b = f \bmod 2^{10}$$



10 LSBs of f can be estimated from bucket number b

10 remaining MSBs are estimated using phase rotation

Estimation Sub-block

Use phase rotation from a time shift τ to estimate the 10 MSBs of f :

$$\theta = \frac{2\pi f\tau}{N} \quad \longrightarrow \quad f = \frac{N\theta}{2\pi\tau}$$

Estimation Sub-block

Use phase rotation from a time shift τ to estimate the 10 MSBs of f :

$$\underbrace{\theta = \frac{2\pi f \tau}{N}} \quad \longrightarrow \quad f = \frac{N\theta}{2\pi\tau}$$

If $\tau > 1$, phase wraps around 2π



$f_1 \neq f_2$ create same phase rotation
→ loose highest MSBs



Use time shift $\tau = 1$ to get MSBs

Estimation Sub-block

Use phase rotation from a time shift τ to estimate the 10 MSBs of f :

$$\theta = \frac{2\pi f \tau}{N}$$



$$f = \frac{N\theta}{2\pi\tau}$$

If $\tau > 1$, phase wraps around 2π



$f_1 \neq f_2$ create same phase rotation
→ loose highest MSBs



Use time shift $\tau = 1$ to get MSBs



Noise in θ creates error



Use large time shift τ to average noise in θ

Estimation Sub-block

Use phase rotation from a time shift τ to estimate the 10 MSBs of f :

$$\theta = \frac{2\pi f \tau}{N}$$



$$f = \frac{N\theta}{2\pi\tau}$$

If $\tau > 1$, phase wraps around 2π



$f_1 \neq f_2$ create same phase rotation
→ loose highest MSBs



Use time shift $\tau = 1$ to get MSBs



Noise in θ creates error



Use large time shift τ to average noise in θ

Use two different time shifts

$\tau = 1$ and $\tau = 32$ to estimate the 10 MSBs of f

Estimation Sub-block

Frequency Recovery from 2^{10} bucketization

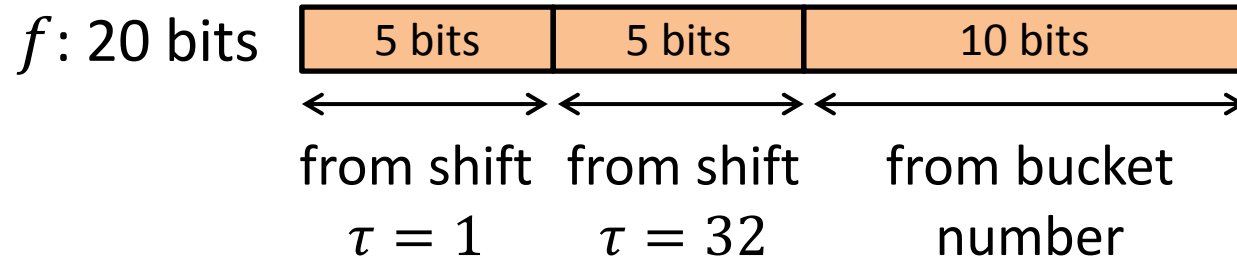

Estimation Sub-block

Frequency Recovery from 2^{10} bucketization

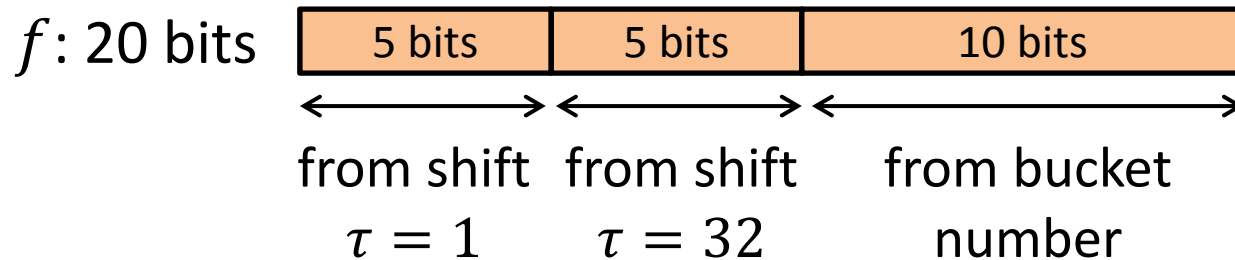

Problem: Small error propagates

→ Affect MSBs

Solution: Use 3 bit overlap to detect errors

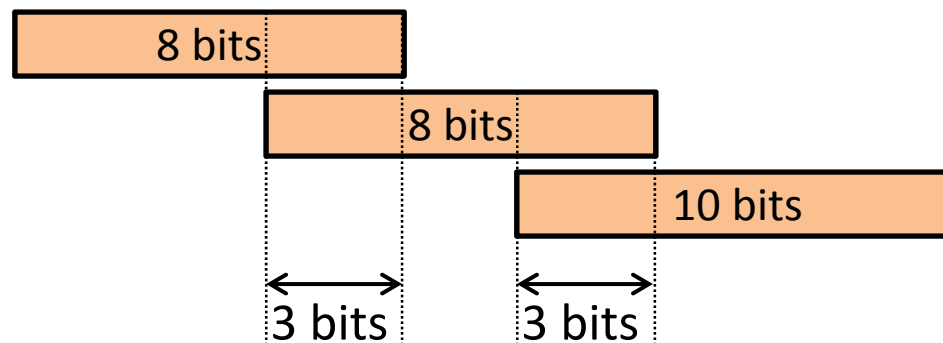

Estimation Sub-block

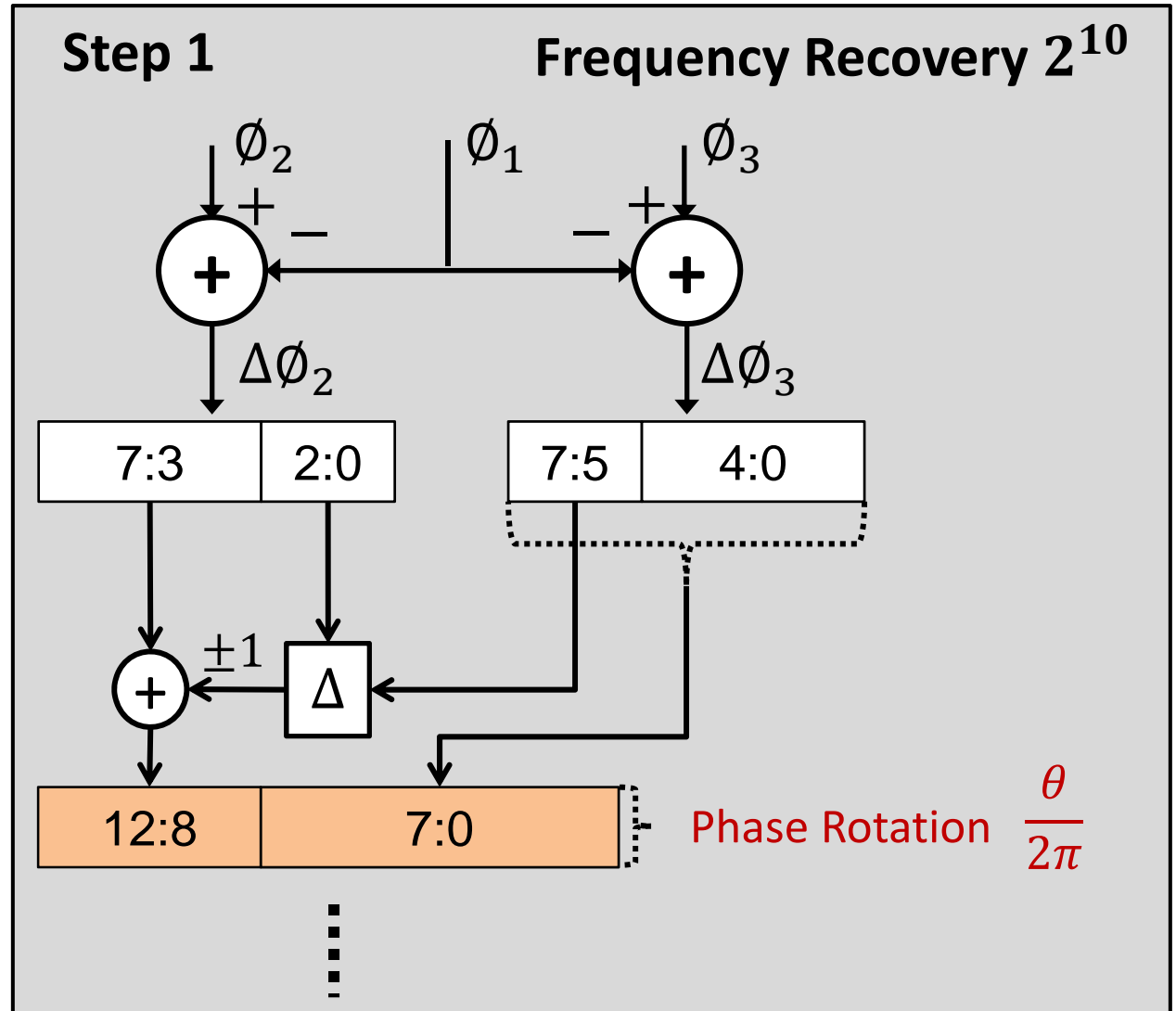
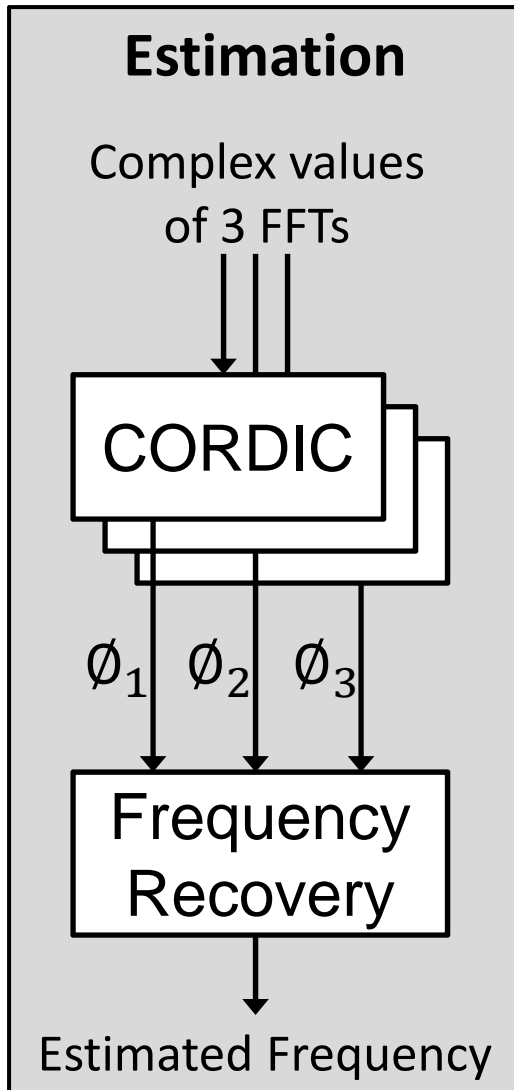

Estimation Sub-block

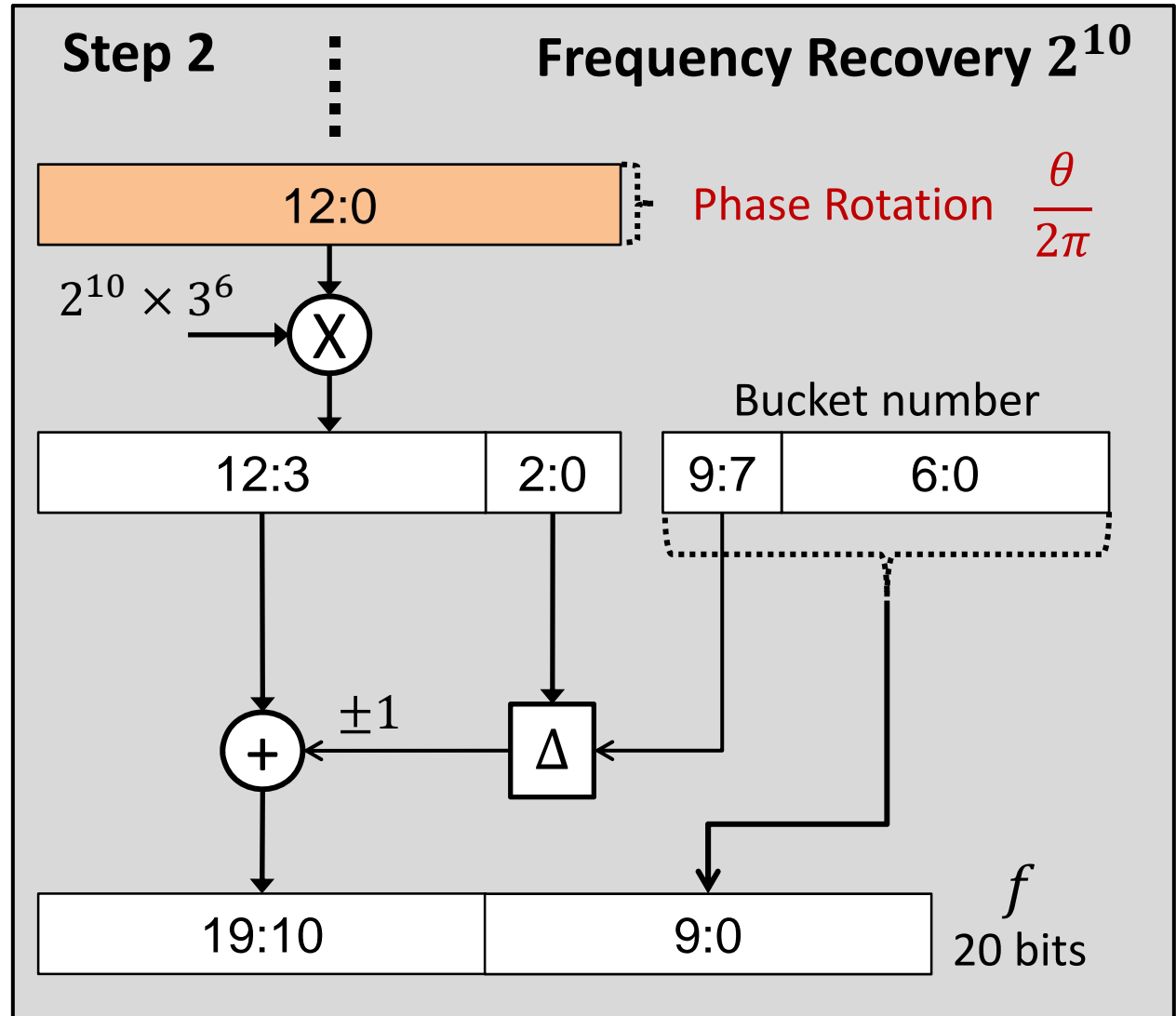
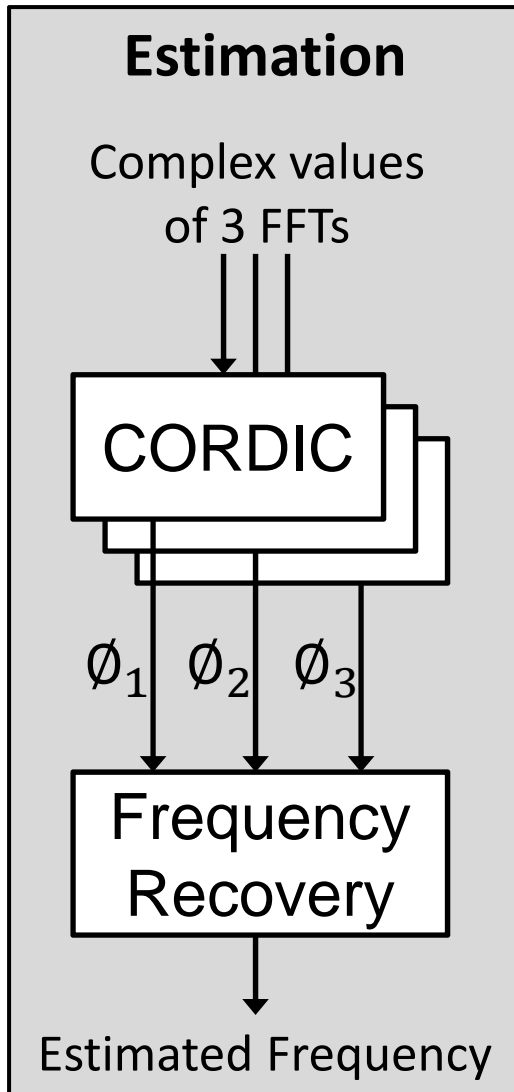

Estimation Sub-block

- For 3^6 bucketization: frequency f aliases to bucket number b :

$$b = f \bmod 3^6$$

- LSBs cannot be replaced directly by the bucket number
- Naïve implementation:
 1. Estimate f from the phase rotation
 2. Calculate the remainder ($f \bmod 3^6$)
 3. Subtract this remainder from f
 4. Then add the bucket number b
- Steps 2 and 3 are done indirectly by truncating the LSBs of θ

$$f = \frac{N\theta}{2\pi\tau}$$

Estimation Sub-block

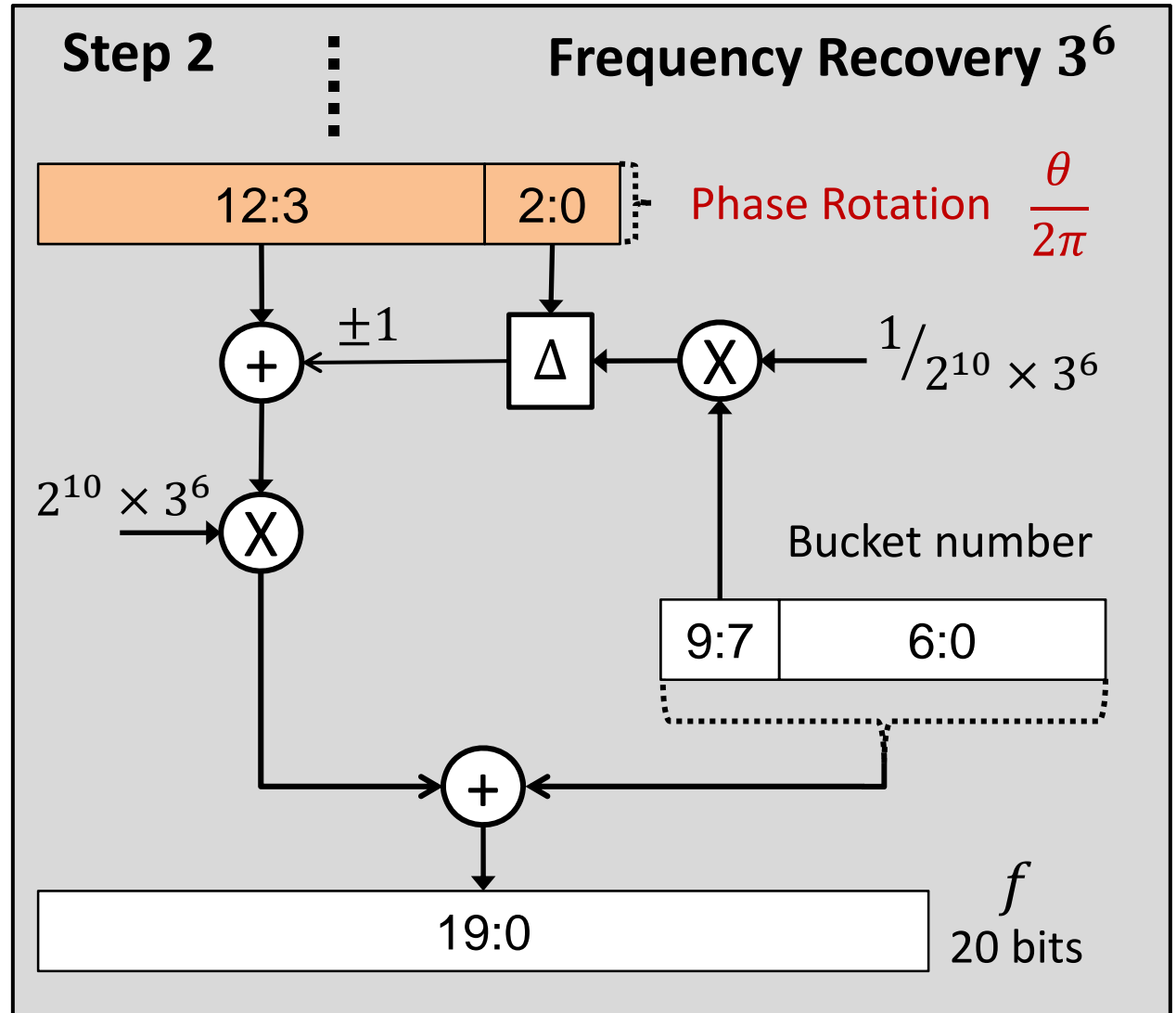
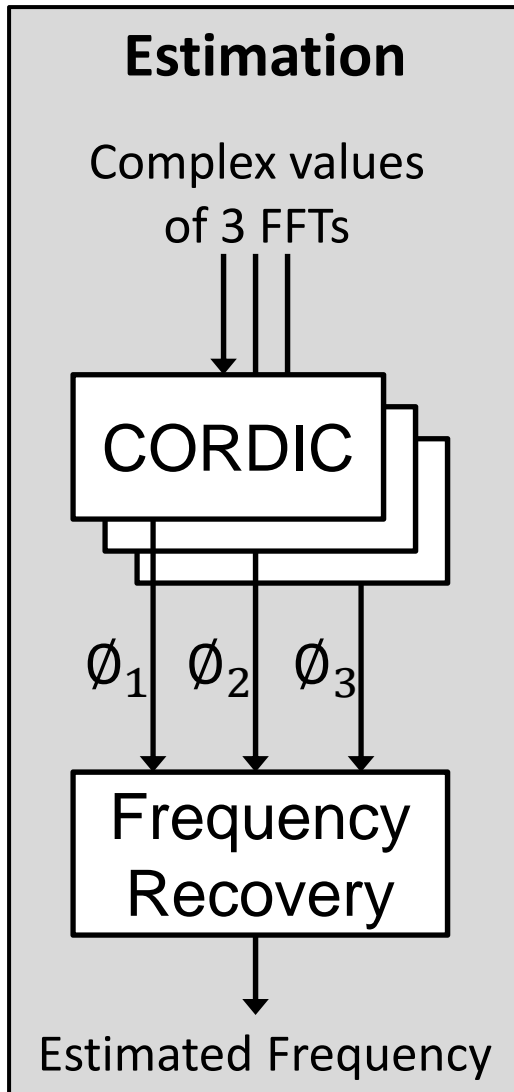

Sparse FFT Chip Block Diagram

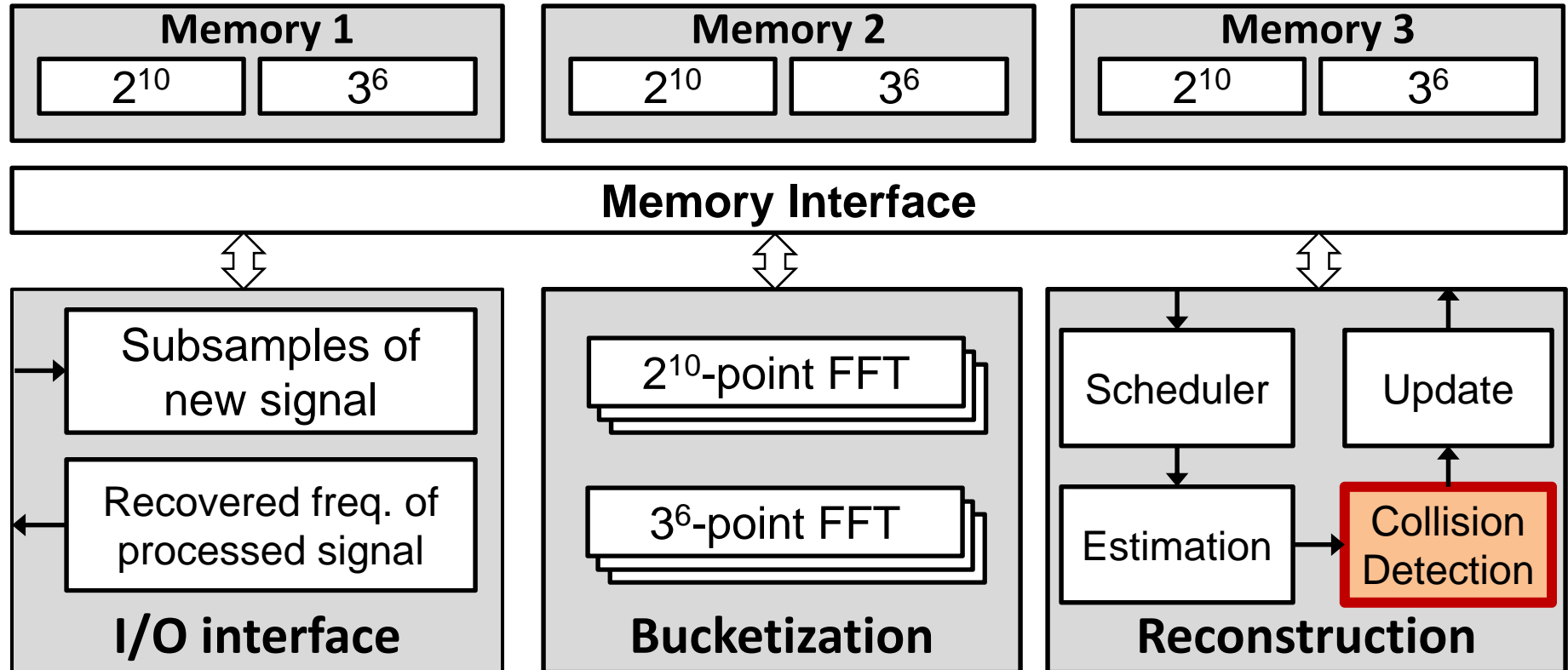

Collision Detection

- No Collision:
 - Single active frequency
 - Time shift causes only change in phase and not in magnitude of the bucket

Collision Detection

- No Collision:
 - Single active frequency
 - Time shift causes only change in phase and not in magnitude of the bucket
- Collision:
 - Multiple active frequencies sum up with different phase rotations
 - Time shift causes the magnitude of the bucket to change

Die photo

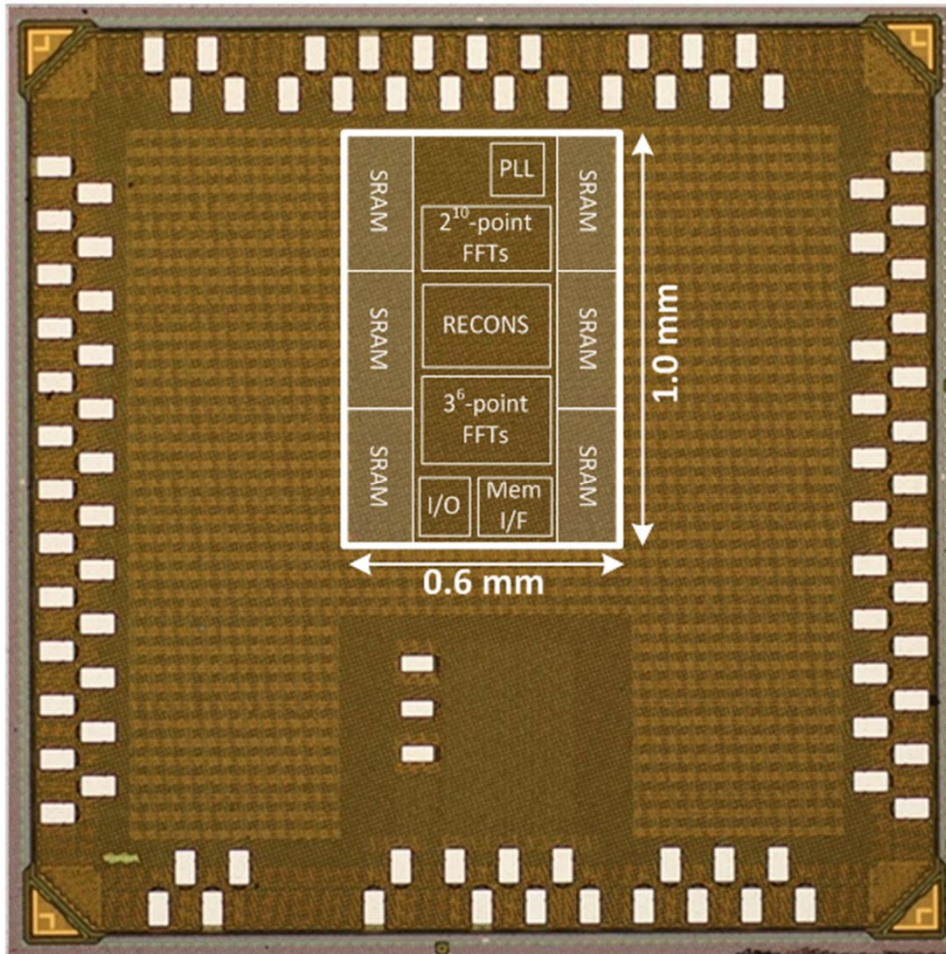

Technology	45nm SOI CMOS
Core Area	0.6mm x 1.0mm
Core Supply Voltage	0.66-1.18 V
Clock Frequency	0.5-1.5 GHz
Core Power	14.6 - 174.8 mW
Latency	63 - 21 μ s

Measurement Result

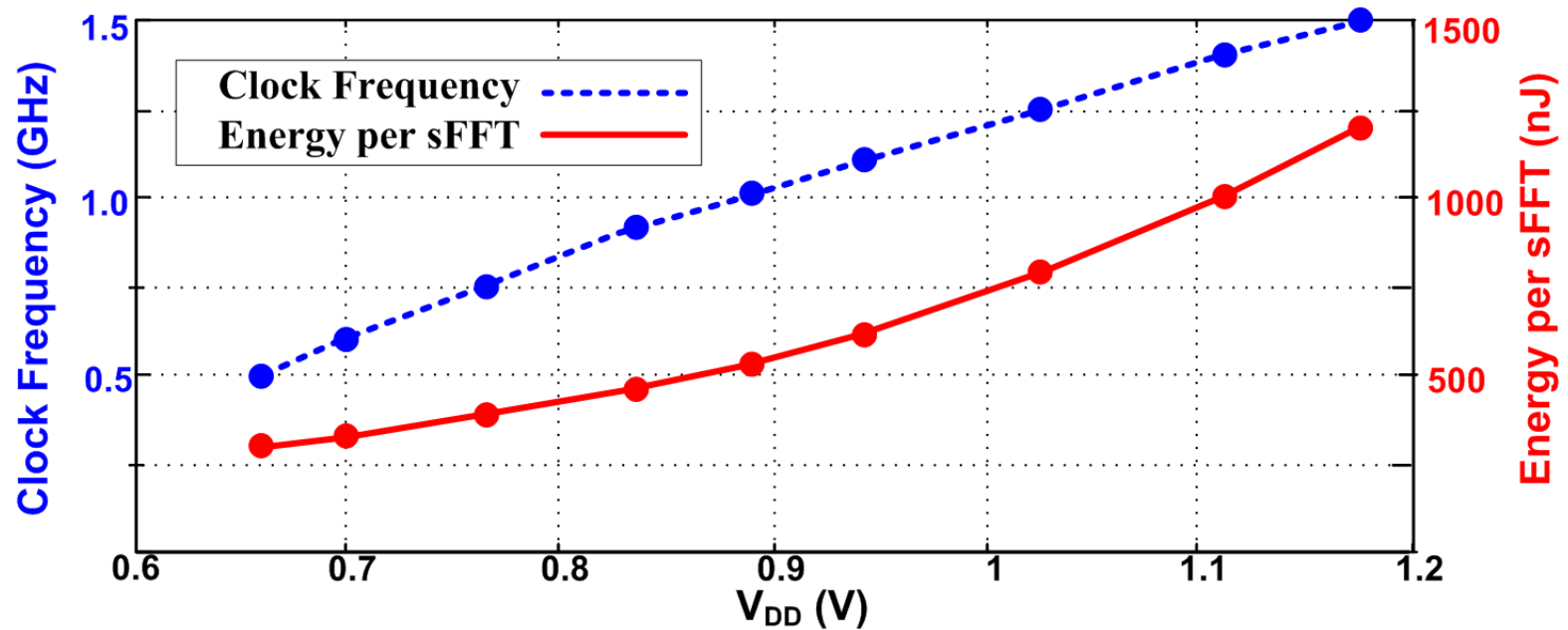

Measurement Result

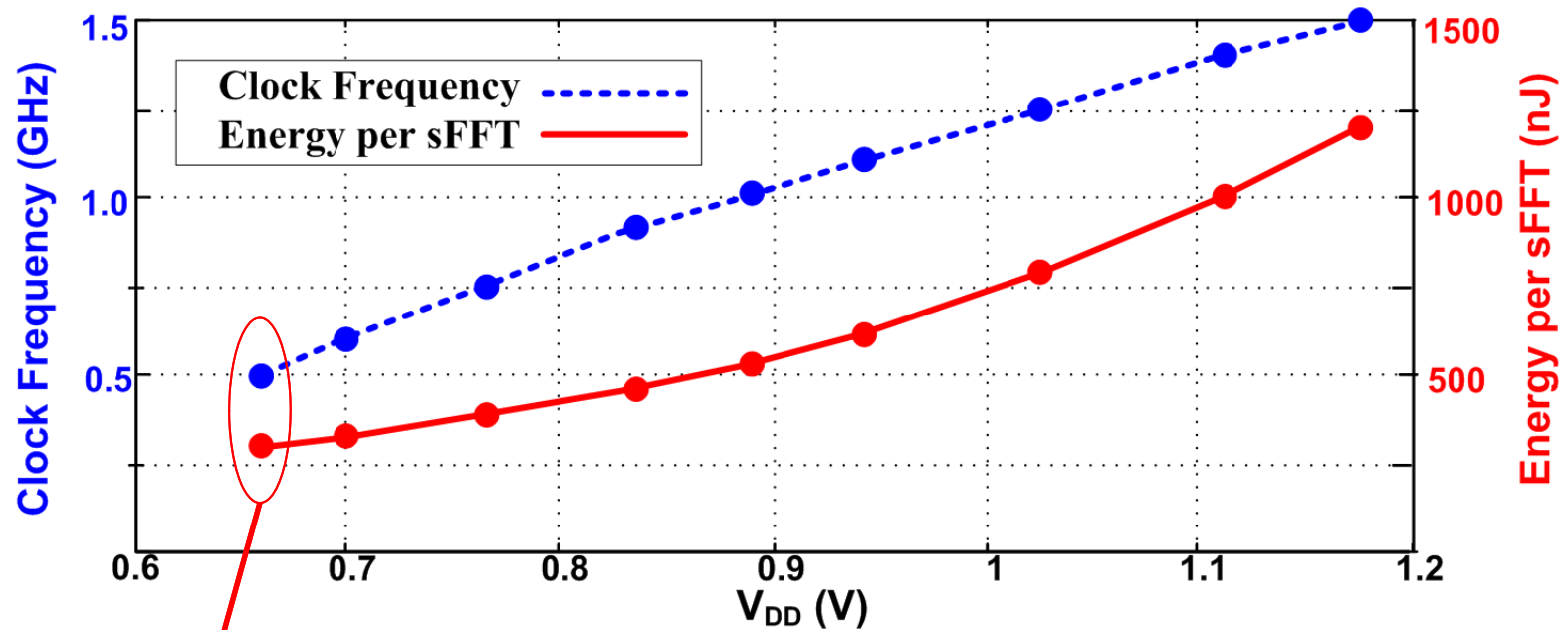

(0.66 V, 500 MHz)
48 sFFT/ms
298 nJ/sFFT

Measurement Result

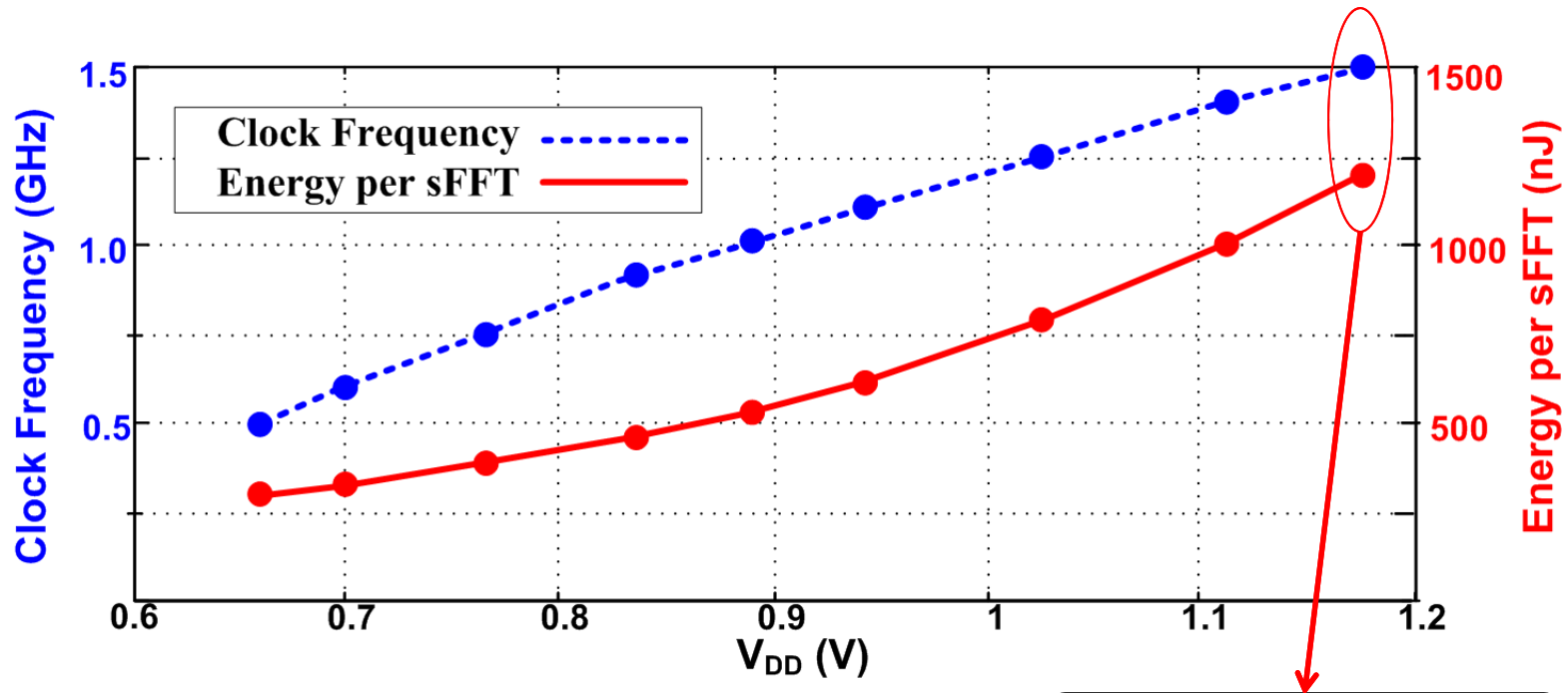

**88x Speed up over
intel i7 (3.4GHz)**

**(1.18 V, 1.5 GHz)
146 sFFT/ms
1.2 μ J/sFFT**

Measurement Result

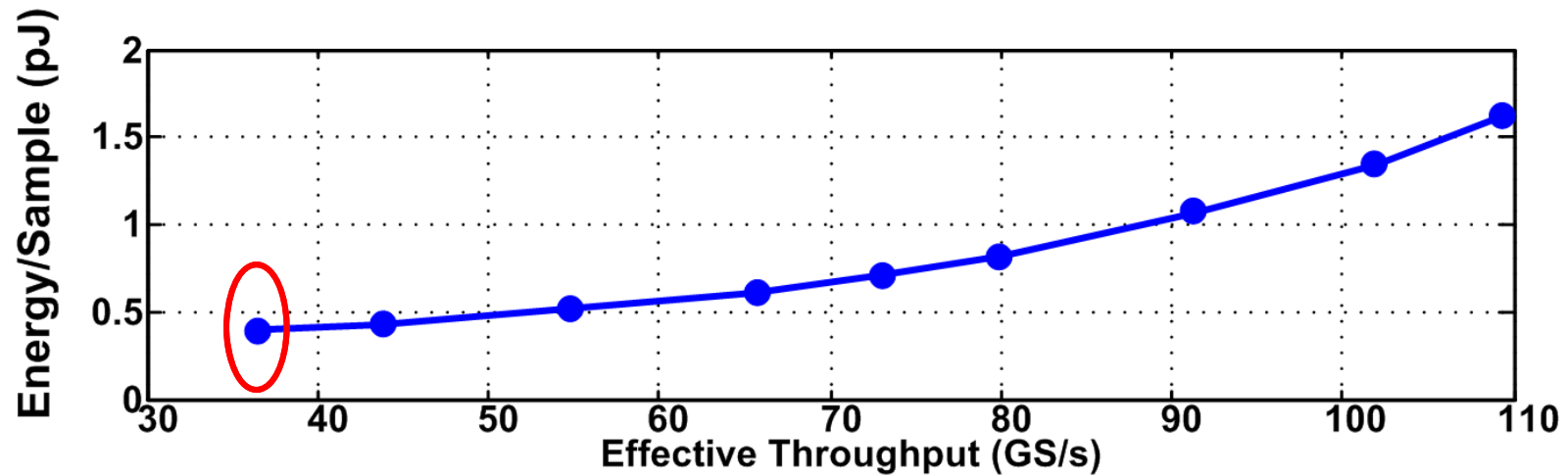

At 0.66V:

- Effective throughput 36GS/s
- Consuming 0.4pJ/sample

Comparison

	ISSCC'11	JSSC'08	JSSC'12	This work
Technology	65 nm	90 nm	65nm	45 nm
Signal Type	Any Signal	Any Signal	Any Signal	Freq.-Sparse signal
Size	2^{10}	2^8	2^7 to 2^{11}	$3^6 \times 2^{10}$
Word width	16 bits	10 bits	12 bits	12 bits
Area	8.29mm ²	5.1mm ²	1.37mm ²	0.6mm ²
Effective Throughput	240MS/s	2.4GS/s	1.25-20MS/s	36-109GS/s
Energy/Sample	17.2pJ	50pJ	19.5-50.6pJ	0.4-1.6pJ

Comparison

	ISSCC'11	JSSC'08	JSSC'12	This work
Technology	65 nm	90 nm	65nm	45 nm
Signal Type	Any Signal	Any Signal	Any Signal	Freq.-Sparse signal
Size	2^{10}	2^8	2^7 to 2^{11}	$3^6 \times 2^{10}$
Word width	16 bits	10 bits	12 bits	12 bits
Area	8.29mm ²	5.1mm ²	1.37mm ²	0.6mm ²
Effective Throughput	240MS/s	2.4GS/s	1.25-20MS/s	36-109GS/s
Energy/Sample	17.2pJ	50pJ	19.5-50.6pJ	0.4-1.6pJ

Sparse FFT works only for frequency-sparse signals

Comparison

	ISSCC'11	JSSC'08	JSSC'12	This work
Technology	65 nm	90 nm	65nm	45 nm
Signal Type	Any Signal	Any Signal	Any Signal	Freq.-Sparse signal
Size	2^{10}	2^8	2^7 to 2^{11}	$3^6 \times 2^{10}$
Word width	16 bits	10 bits	12 bits	12 bits
Area	8.29mm ²	5.1mm ²	1.37mm ²	0.6mm ²
Effective Throughput	240MS/s	2.4GS/s	1.25-20MS/s	36-109GS/s
Energy/Sample	17.2pJ	50pJ	19.5-50.6pJ	0.4-1.6pJ

Comparison

	ISSCC'11	JSSC'08	JSSC'12	This work
Technology	65 nm	90 nm	65nm	45 nm
Signal Type	Any Signal	Any Signal	Any Signal	Freq.-Sparse signal
Size	2^{10}	2^8	2^7 to 2^{11}	$3^6 \times 2^{10}$
Word width	16 bits	10 bits	12 bits	12 bits
Area	8.29mm ²	5.1mm ²	1.37mm ²	0.6mm ²
Effective Throughput	240MS/s	2.4GS/s	1.25-20MS/s	36-109GS/s
Energy/Sample	17.2pJ	50pJ	19.5-50.6pJ	0.4-1.6pJ

Comparison

	ISSCC'11	JSSC'08	JSSC'12	This work
Technology	65 nm	90 nm	65nm	45 nm
Signal Type	Any Signal	Any Signal	Any Signal	Freq.-Sparse signal
Size	2^{10}	2^8	2^7 to 2^{11}	$3^6 \times 2^{10}$
Word width	16 bits	10 bits	12 bits	12 bits
Area	8.29mm ²	5.1mm ²	1.37mm ²	0.6mm ²
Effective Throughput	240MS/s	2.4GS/s	1.25-20MS/s	36-109GS/s
Energy/Sample	17.2pJ	50pJ	19.5-50.6pJ	0.4-1.6pJ

Conclusion

- 0.75 million-point sparse FFT in 45nm CMOS IBM SOI
- More than 40x better energy efficiency than traditional FFTs
- 88x improvement in run-time over the software implementation



INSTITUTE OF ELECTRICAL AND ELECTRONICS ENGINEERS

ISSCC®

UNIVERSITY OF PENNSYLVANIA